

GEMINI - II M

Double Head Saw Ø 400 mm

PRODUCT WEB LINK

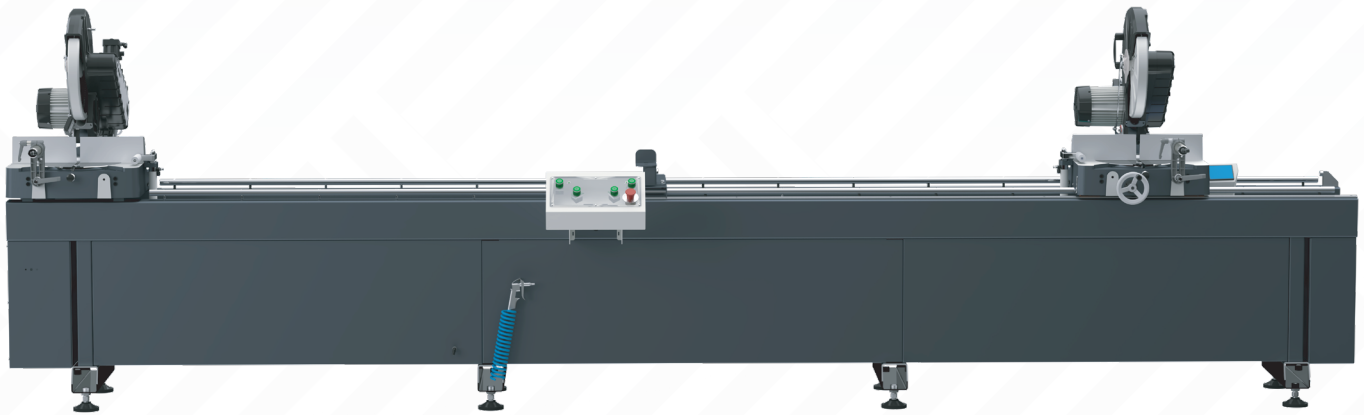

WEB

The GEMINI – II M, a manual, button-controlled double-head cutting machine with a 400 mm saw, is ideal for cutting aluminum, PVC, and wood profiles at various angles and thicknesses. The GEMINI – II M provides manual, fast positioning thanks to its X-axis control with a handwheel and ruler, while delivering a perfect cutting process. The GEMINI – II M, with its automatic horizontal and vertical clamps and profile support unit, enhances cutting quality while prioritizing its economic feature.

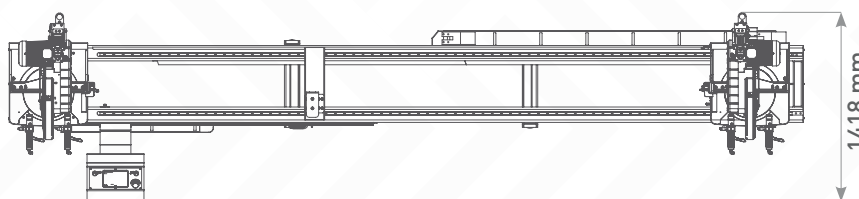
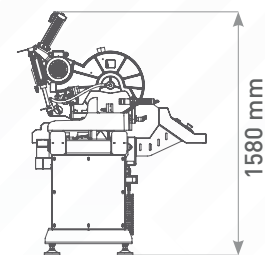
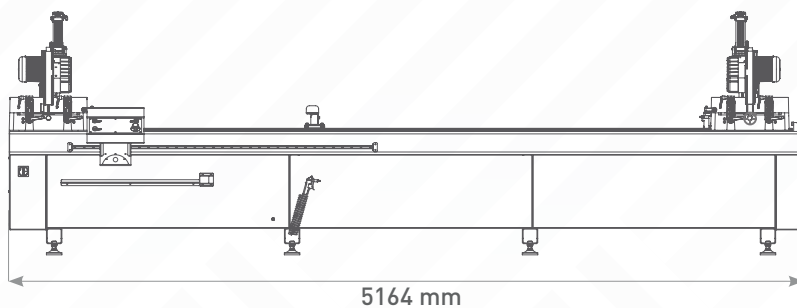
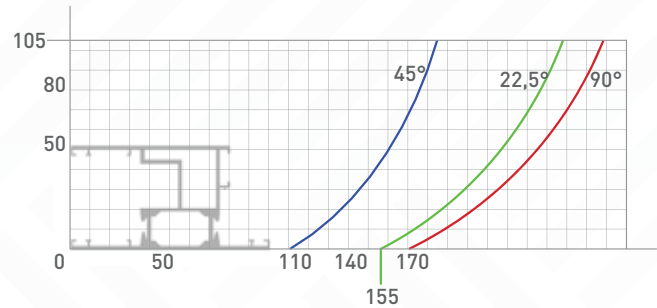
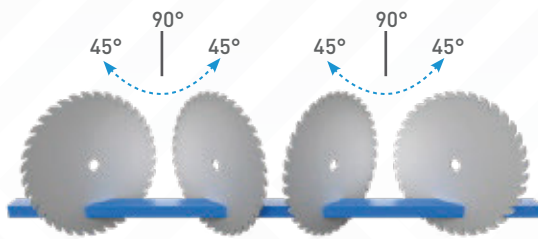

GEMINI - II M

Double Head Saw Ø 400 mm

AXIS TRAVEL

Manual control X axis	•
Moving head positioning control with linear scale	•
Hydro-pneumatic cutting feed adjustment	•
Minimum cutting length with double head	610 mm
Maximum cutting length with double head	4550 mm
Maximum internal rotation angle	45°
Maximum external rotation angle	-45°

AIR

Pressure	6-8 Bar
Consumption	50 L/min

ELECTRICAL

Maximum power	5,45 kW
Voltage	400V
Frequency	50-60 Hz

OPERATIONAL AREA

Cemented carbide saw blade	2
Saw blade diameter	400 mm
Saw blade motor power	2.2kW - 3HP
Optional length in X-axis	○
Horizontal pneumatic clamps	•
Vertical pneumatic clamps	•
Intermediate profile support (pcs)	1
Additional intermediate profile support	○
Spray saw cooling system	•
Saw blade travel speed adjustment	•

• Standard ○ Opsiyonel